

GRADE 8
NATURAL SCIENCES

REVISION BOOKLET (2021)

QUESTION PAPER A _ Page 1
QUESTION PAPER B _ Page 9
QUESTION PAPER C _ Page 17

—
—
—

CONTENT

LIFE AND LIVING (Term 1)
MATTER AND MATERIAL (Term 2)

REVISION QUESTION PAPER A**SECTION A****QUESTION 1**

1.1 Various options are provided as possible answers to the following questions. Choose the answer and write only the letter (A – D) next to the question number (1.1.1 – 1.1.10).

1.1.1 During the test for starch, a green leaf is placed in boiling alcohol to ...

- A break the cell walls.
- B to extract the chlorophyll.
- C to remove starch.
- D stop metabolic processes. (1)

1.1.2 Which one of the following is arranged from largest to smallest?

- A Population, community, ecosystem, biosphere.
- B Ecosystem, biosphere, community, population. C Biosphere, ecosystem, community, population.
- D Biosphere, ecosystem, population, community. (1)

Questions 1.1.3 and 1.1.4 are based on the diagram of the food chain below. Study it and answer the questions.

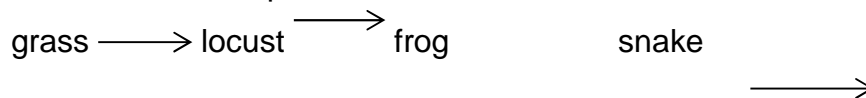

1.1.3 What do the arrows in the food chain above indicate?

- A Trophic levels.
- B Who consumes/eats whom.
- C Flow of energy.
- D A common food chain. (1)

1.1.4 In the food chain shown above, which organism is the autotroph?

- A Snake
- B Locust
- C Frog
- D Grass (1)

1.1.5 Which one of the following causes malaria in humans?

- A Protista.
- B Fungi.
- C Bacteria.

- D Viruses.
(1)

1.1.6 What are the horizontal rows on the Periodic Table called?

- A Groups
B Columns
C Families
D Periods (1)

1.1.7 If an atom has 12 protons in the nucleus, then it must also have ... to be neutral.

- A 12 protons around the nucleus
B 12 neutrons in the nucleus
C 12 electrons around the nucleus
D 12 electrons in the nucleus (1)

1.1.8 Which of the following is a property of a solid?

- A It flows.
B The particles slide past each other.
C It undergoes a phase change.
D It has a defined shape.
(1)

1.1.9 Melting is the change in state of a...

- A liquid to a solid.
B liquid to a gas.
C solid to a gas.
D solid to a liquid.
(1)

1.1.10 Water is different from other substances because it is ...

- A more dense as a solid than a liquid.
B less dense as a solid than a liquid.
C more dense as a solid than a gas.
D less dense as a solid than a gas. (1)

[10]

1.2 Give **ONE word/term** for each of the following statements. Write only the word/term next to the question number.

- 1.2.1 A sub-atomic particle with a positive charge.
(1)

- 1.2.2 The spontaneous spreading of particles from an area of high concentration to an area of low concentration. (1)
- 1.2.3 The amount of mass per unit volume. (1)
- 1.2.4 A substance that cannot be broken down into simpler substances by chemical methods. (1)
- 1.2.5 Matter that can flow and does not have a specific shape. (1)

[5]

SECTION A: [15]

SECTION B

QUESTION 2

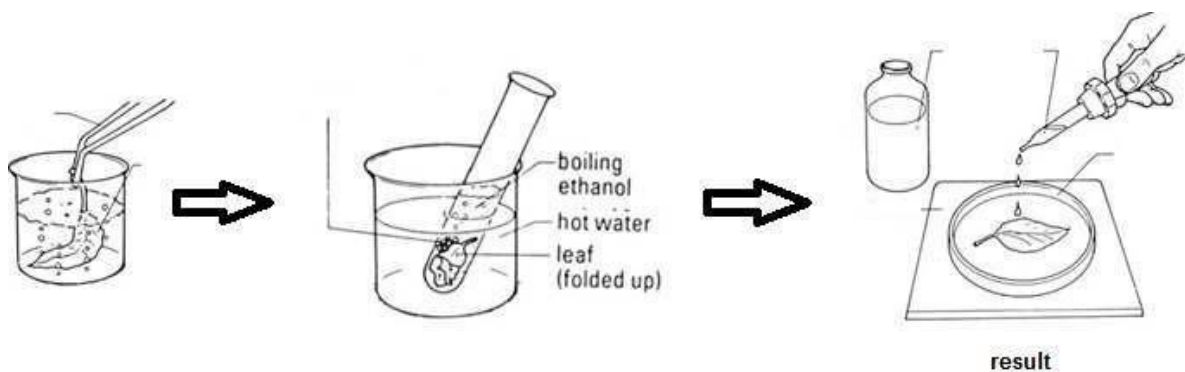

2.1 The diagram below illustrates the apparatus used in an experiment.

- 2.1.1 Identify the experiment illustrated by the diagrams. (1)
- 2.1.2 Write down a hypothesis for this experiment. (2)
- 2.1.3 Identify independent variable. (1)
- 2.1.4 Identify dependent variable. (1)
- 2.1.5 Explain what the result of the iodine indicates. (2)

[7]

QUESTION 3

- 3.1 The following food web shows the feeding relationships between organisms in a Savannah ecosystem. Answer the questions that follow.

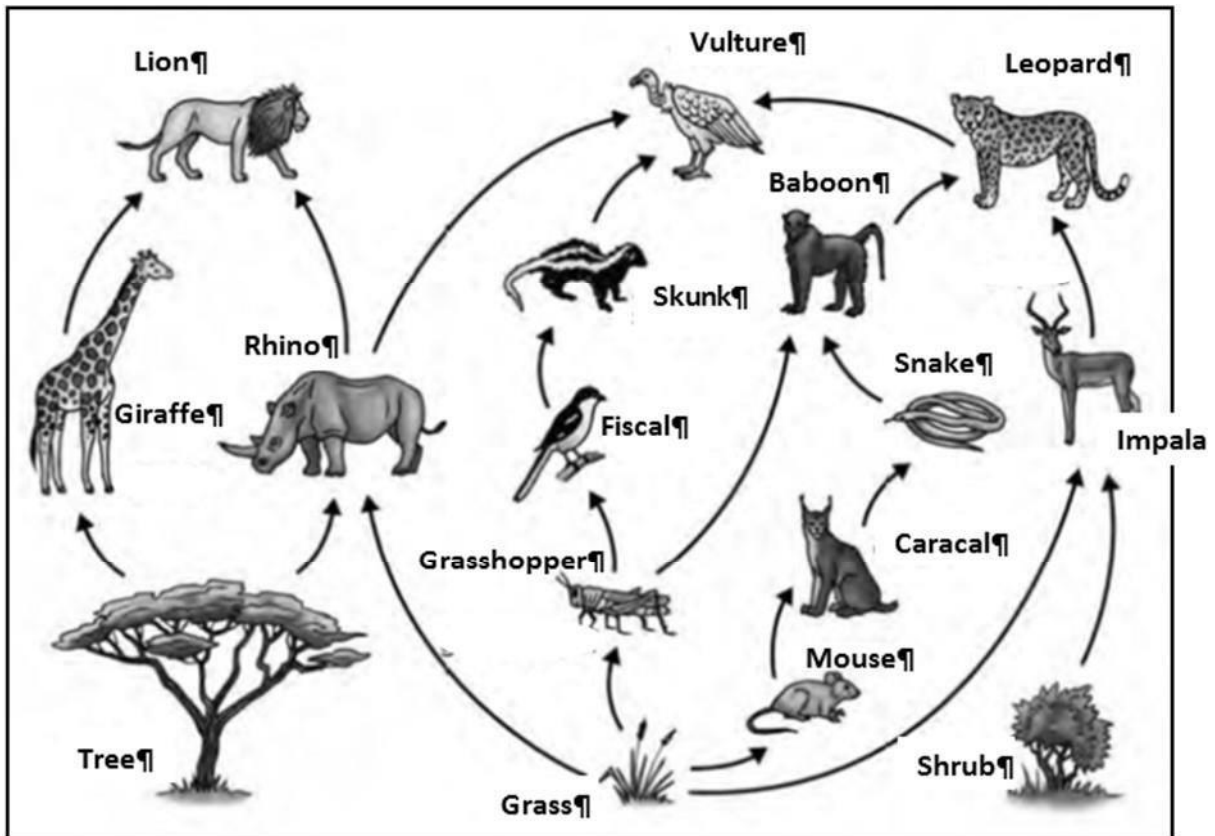

- 3.1.1 Explain in your own words what an ecosystem is. (2)
- 3.1.2 Why is it important that an animal adapt to its environment? (1)
- 3.1.3 How is the leopard adapted to his environment? (2)
- 3.1.4 In a balanced ecosystem, there are more impala than leopards. Explain why this is so. (2)
- 3.1.5 Due to veld fires, a large number of the shrubs, trees and grassland are destroyed that forms part of the above-mentioned ecosystem. Explain how this destruction will influence the ecosystem. (2)

3.2 The accompanying diagram represents an ecological pyramid of a certain food chain in nature.

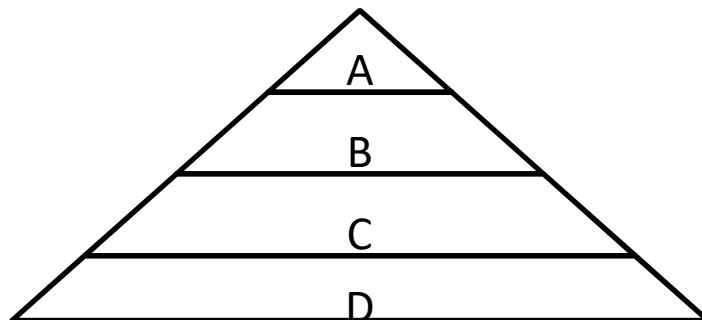

- 3.2.1 Which LETTER represents the producers? What is the main role of the producers in the food chain? (2)
- 3.2.2 Why are there usually only a few organisms at the top of an ecological pyramid? (2)

3.2.3 What type of consumer is represented by the letter **C**? (1)

3.2.4 Which **TWO** letters represent carnivores? (2)

3.2.5 Which type of organism is not represented in the diagram? (1)

[17]

SECTION C QUESTION 4

4.1 Use the Periodic Table of elements provided to write down the **NAME** of an element that:

4.1.1 is a non-metal in Group 1. (1)

4.1.2 is represented by the symbol **Na**. (1)

4.1.3 has six protons in the nucleus of one atom. (1)

4.1.4 is a noble gas in period 2. (1) 4.1.5

is in Group 2, Period 3. (1)

4.2 Marius collected some seawater near the beach. The seawater tasted salty and was full of fine sand. He separated the sand from the seawater using the apparatus shown below.

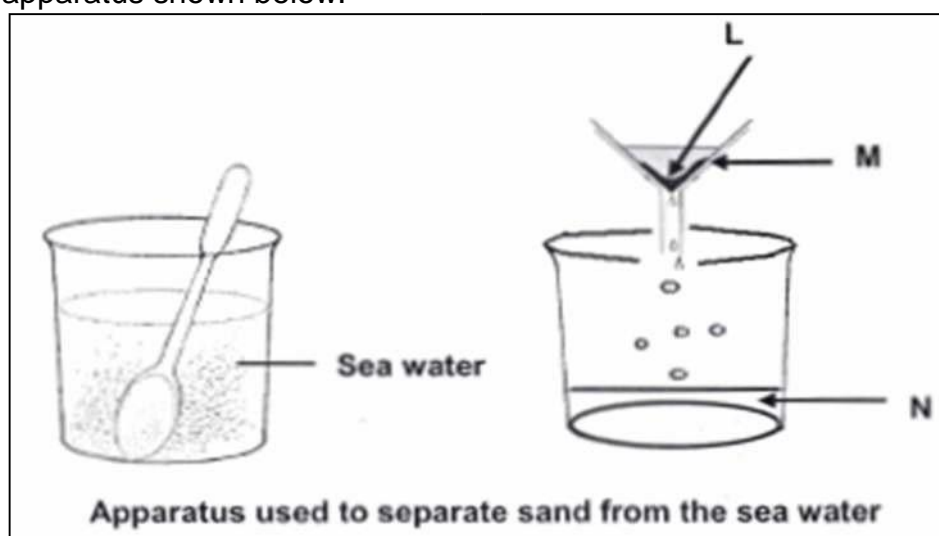

4.2.1
Name the

apparatus labelled **M**. (1)

4.2.2 Name the method used here to separate the sand from the seawater. (1)

4.2.3 Substance **L** was retained by the filter paper. Give the name of the substance. (1)

4.2.4 Substance **N** passed through the filter paper. Name one ingredient of substance **N**. (1)

[9]

QUESTION 5

5.1 The particle model of matter can be used to represent different substances.

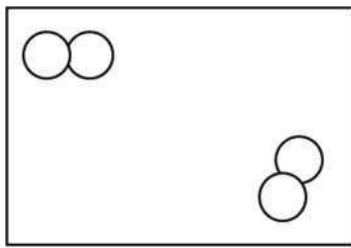

A

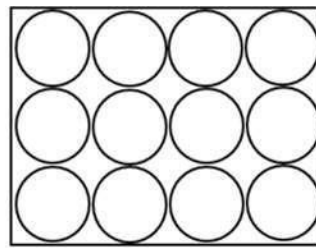

B

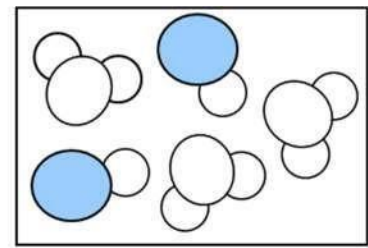

C

5.1.1 Which diagram, **A**, **B** or **C**, represents a diatomic molecule? Give a reason for your answer. (2)

5.1.2 Compare the three phases of matter in terms of the forces between the particles. (3)

5.1.3 How many types of molecules are found in diagram **C**? (1)

5.1.4 Which diagram represents particles with the highest average kinetic energy? Explain your answer in terms of the particle model of matter. (2)

5.1.5 Why does diffusion not take place in **B**? (2)

5.2 A learner sets up the apparatus shown below to measure the volume of a steel ball. Study the diagrams and answer the questions that follow.

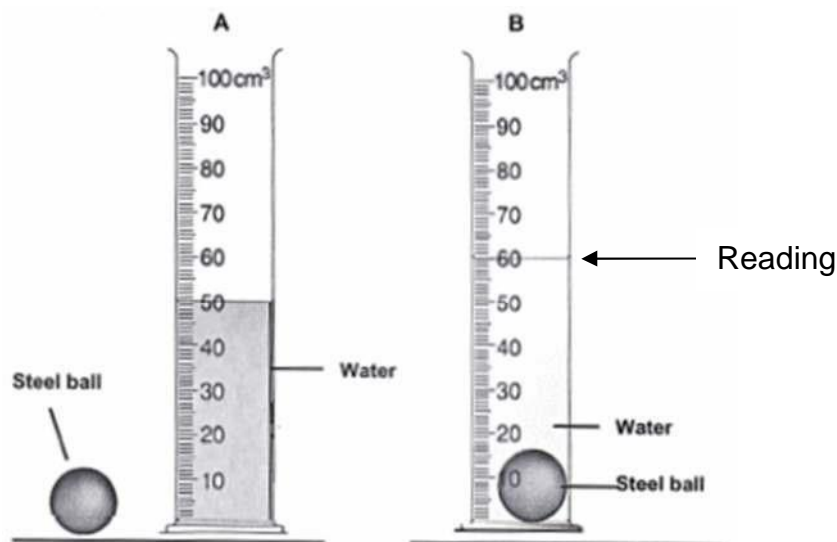

The apparatus set up to measure the volume a steel ball

5.2.1 Give the name of the apparatus, which is used to measure the volume of the steel ball. (1)

5.2.2 When a steel ball is carefully placed into apparatus **A**, the water level increases to show a new volume as shown in **B**. Write down the new reading for the volume of the water in apparatus **B**. (1)

5.2.3 Calculate the volume of the steel ball from the information shown above. Show all your calculations. (2)

5.2.4 Explain why the steel ball drops to the bottom.

(1)

[15]

QUESTION 6

A chemical reaction is represented by the following diagram:

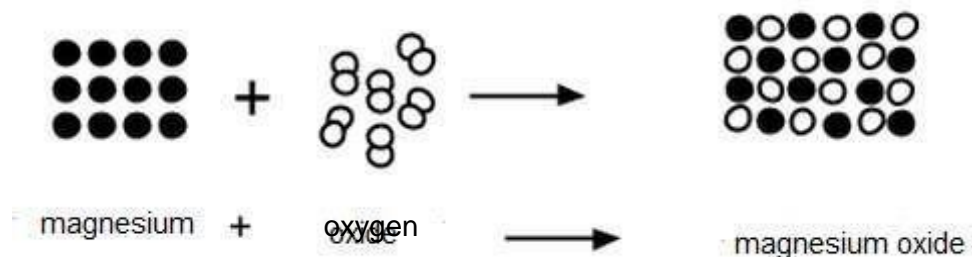

6.1 Write the name of the product(s) for this reaction.

(1)

6.2 Describe in which way the atoms in this reaction are the same before and after the reaction.

(2)

6.3 Describe in which way the atoms in this reaction differ before and after the reaction.

(2)

6.4 In which phase does the product occur? Give a reason for your answer visible in the diagram.

(2)

[7]

SECTION B AND C: 55

GRAND TOTAL: 70 REVISION

QUESTION PAPER B SECTION A

QUESTION 1

1.1 Various options are provided as possible answers to the following questions.

Choose the answer and write only the letter (A – D) next to the question number (1.1.1 – 1.1.10).

1.1.1 The most important source of light and heat on Earth is ...

- A oil.
- B electricity.
- C the Sun.
- D volcanoes.

(1)

1.1.2 The products of photosynthesis are ...

- A glucose and oxygen.
- B carbon dioxide and water.
- C glucose and carbon dioxide.
- D carbon dioxide and oxygen.

(1)

1.1.3 Ecology is ...

- A a combination of all ecosystems.
- B the study of the interactions of organisms with each other and their physical and chemical environment.
- C a community of animals, plants and people.
- D a group of people that stays in one place that has a specific common characteristic. (1)

1.1.4 The following is an example of a biotic component of an ecosystem.

- A A clean cement dam that contains only water.
- B The wind.
- C Heat.
- D A grassland. (1)

1.1.5 The following is NOT an example of a micro-organism.

- A Virus.
- B Mushroom.
- C Bacterium.
- D Protista. (1)

1.1.6 Atoms consist of ...

- A elements and compounds.
- B neutrons, electrons and compounds.
- C protons, electrons and neutrons.
- D elements, compounds, neutrons, electrons and protons. (1)

1.1.7 The following particles are found in the nucleus of an atom:

- A Neutrons and electrons.
- B Neutrons, elements and electrons.
- C Protons and neutrons
- D Protons, electrons and neutrons. (1)

1.1.8 The melting point of element X is 25°C. The boiling point of the same element is 70°C. At 30°C the element is a ...

- A solid.
- B liquid.
- C gas.
- D vapour. (1)

1.1.9 In which one of the following substances will the distances between the particles inside the substance be the greatest? All substances shown have the same volume.

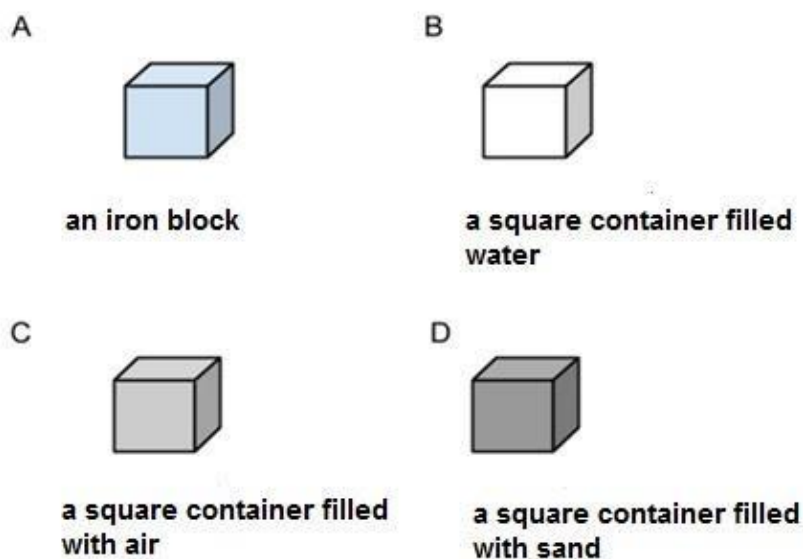

(1)

1.1.10 The reactants in a chemical reaction are ...

- A all the substances that appear in the solid phase.
B the new substances that are formed.
C all the substances that are involved.
D all the substances that react with each other. (1)

[10] 1.2 Give **ONE word/term** for each of the following statements.
Write down only the word/term next to the question number.

- 1.2.1 The process whereby energy is released from food through a range of chemical reactions. (1)
- 1.2.2 The term used for the various stages in the food chain. (1)
- 1.2.3 Living objects that are too small to view with the naked eye and can only be observed through a microscope. (1)
- 1.2.4 Positively charged particles in the nucleus of an atom. (1)
- 1.2.5 The name of the scientific theory that explains that all matter (solids, liquids and gases) consists of particles. (1)

[5]**TOTAL SECTION A: 15****SECTION B QUESTION 2**

The following diagram illustrates two life sustaining processes. Answer the questions that follow:

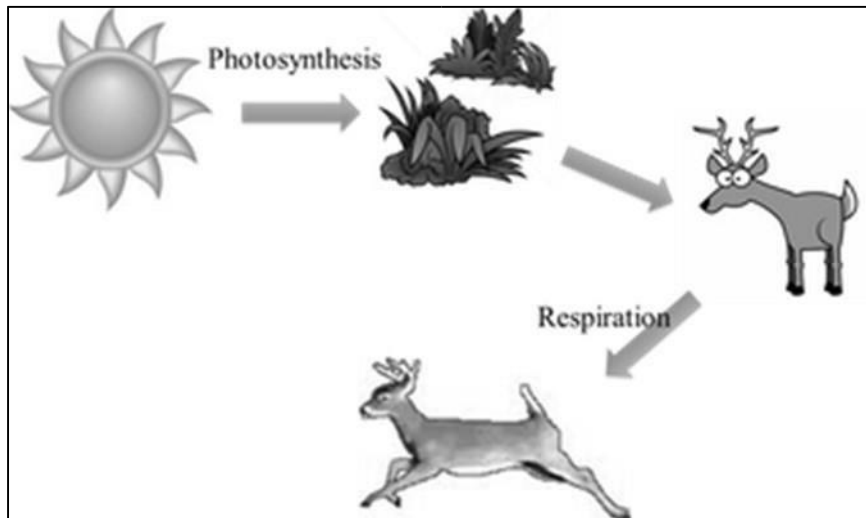

- 2.1. Describe the process of photosynthesis. (2)
- 2.2 Write down the word equation for respiration. (2)
- 2.3 Which process will take place in the following organisms? **ONLY** write **PHOTOSYNTHESIS** or **RESPIRATION** or **BOTH**.
- 2.3.1 Animals (1)
- 2.3.2 Plants (1)
- 2.4 Explain the relationship between glucose and starch. (1)
- [7]**

QUESTION 3

- 3.1 Explain the difference between producers and consumers in a food web. (2)
- 3.2 Study the diagram of a food web.

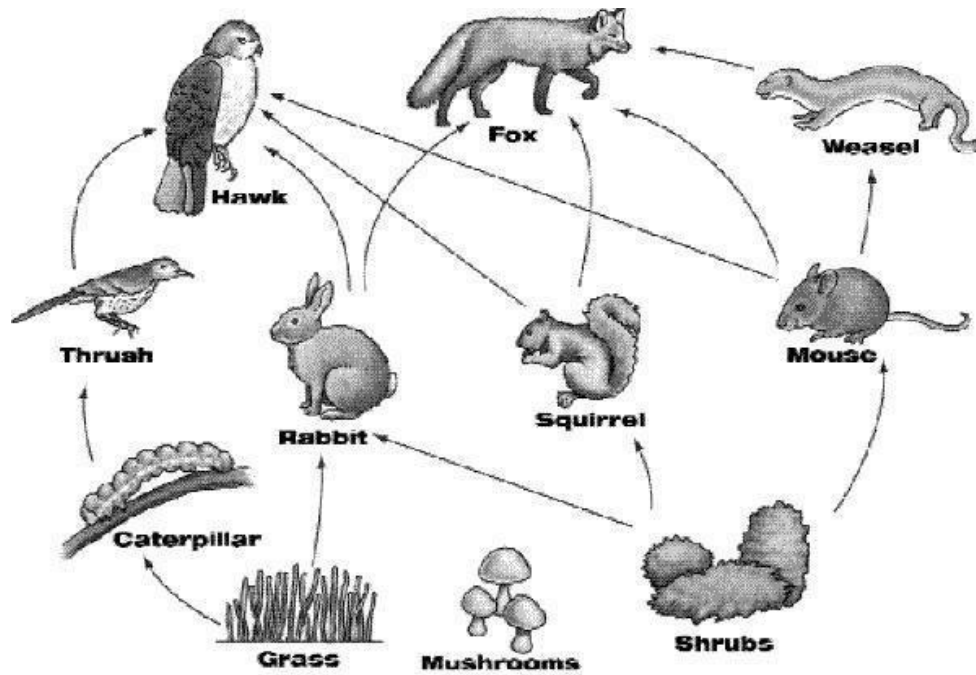

Give an example of each of the following from the food web:

- 3.2.1 A producer (1)
- 3.2.2 A tertiary consumer (1)
- 3.2.3 An insectivore (1)
- 3.2.4 A predator (1)
- 3.3 Explain the impact on the food web if the hawk is removed from the food web. (3)
- 3.4 Listed below are three types of adaptations:

➤ **Structural** ➤ **Functional** ➤ **Behavioural**

Use the list to identify the type of adaptation in each of the following cases:

- 3.4.1 The jaw of a rabbit is adapted for a herbivore diet. (1)
- 3.4.2 Coats of mice grow faster and become thicker when they relocate to colder areas. (1)
- 3.4.3 Hawks have hooked beaks that are designed for tearing off meat. (1)
- 3.4.4 Mushrooms increase the surface area of the gills under their caps to produce more spores. (1)
- 3.5 Explain why it is important that organisms can adapt. (2)

QUESTION 4

Give an **EXAMPLE** for each of the following:

- 4.1 A virus that causes AIDS. (1)
- 4.2 Food that is produced by using micro-organisms. (1)
- 4.3 Medicine that is produced by using micro-organisms. (1)
- 4.4 The name of a scientist that developed a method to remove bacteria by boiling and cooling of liquids. (1)

[4] SECTION C

QUESTION 5

5.1 Different types of substances are represented in the diagrams below. Answer the questions that follow:

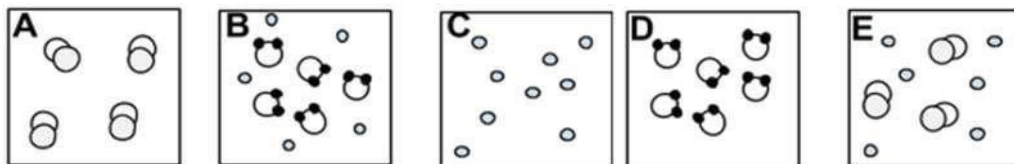

Write down the LETTER of the diagram which best represents:

- 5.1.1 An element that consists of single atoms. (1)
 - 5.1.2 An element that consists of diatomic molecules. (1)
 - 5.1.3 A compound. (1)
 - 5.1.4 A mixture of elements. (1)
- 5.2 Consider the three phases of matter illustrated in the diagram below.

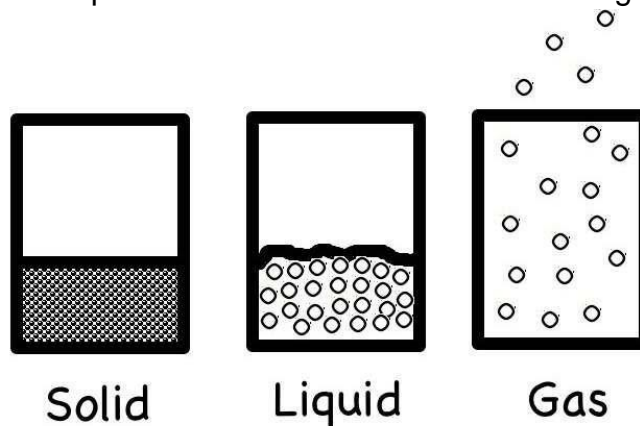

Describe in detail the arrangement and behaviour of particles in a gas. (4)

5.3 When you walk past a bakery, you can smell the fresh bread that is being baked. This is possible due to the diffusion of gases.

- 5.3.1 Explain what diffusion is. (2)
- 5.3.2 How does diffusion that take place in liquids compare to diffusion in gases? (1)
- 5.3.3 Explain why it is NOT possible for diffusion to take place in solids. (2)

[13]

QUESTION 6

6.1 When sand and ice are added to a glass of water, the sand sinks to the bottom of the glass while the ice floats on the water as shown below.

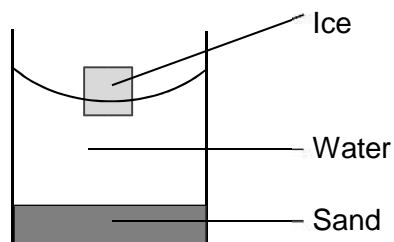

6.1.1 Write down a definition for density. (2)

6.1.2 Write down the three substances (water, sand and ice) in order of INCREASING density. (3)

6.2 Consider the picture of a ship sailing on the sea.

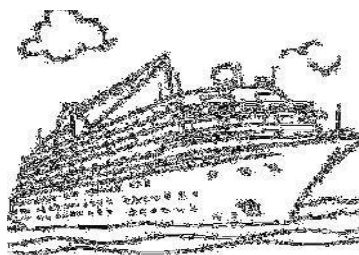

6.2.1 Which one of water and iron has the highest density? (1)

6.2.2 Explain, by referring to density, why a ship can float on water. (2)

6.3 Study the following diagram. An empty paint tin with its lid on, is full of air. When more air is pumped into the tin, the lid pops off at some stage.

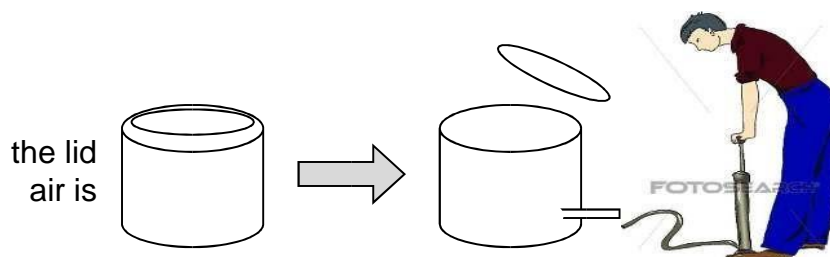

Explain why the lid pops off when more air is pumped into the tin. (3)

[11]

QUESTION 7

7.1 Atoms of oxygen, hydrogen and carbon are represented by the following symbols:



Oxygen



Hydrogen

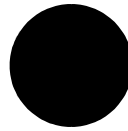

Carbon

Use the above symbols to draw the following:

7.1.1 One water molecule (2)

7.1.2 Carbon + oxygen gas → carbon dioxide (3)

[5]

TOTAL SECTION C: 29

GRAND TOTAL: 70 REVISION

QUESTION PAPER C SECTION A QUESTION 1

1.1 Four options are given as possible answers to the following questions. Every question has only ONE correct answer. Choose an answer and write down only the letter (A – D) next to the question number (1.1 – 1.10).

1.1.1 What are the five levels of environmental organization from the simplest to the most complicated?

- A Biosphere, Ecosystem, Community, Population, Organism
- B Ecosystem, Population, Organism, Community, Biosphere C
- Biosphere, Community, Population, Organism, Ecosystem
- D Organism, Population, Community, Ecosystem, Biosphere (1)

1.1.2 The reason for boiling a green leaf in alcohol during the test for starch is to ...

- A break down the cell walls.
- B extract the chlorophyll.
- C remove starch.
- D stop metabolic processes in the leaf. (1)

1.1.3 A certain plant requires moisture, oxygen, carbon dioxide, light and minerals in order to survive. This statement shows that living organisms depend on...

- A biotic components.
- B abiotic components.
- C symbiotic relationships.
- D carnivore-herbivore relationships. (1)

1.1.4 The following is NOT an example of a micro-organism.

- A Virus.
- B Mushroom.

- C Bacterium.
 - D Protista.
- (1)

1.1.5 Which one of the following statements is FALSE?

- A Malaria is caused by bacteria.
 - B Micro-organisms cannot be seen with the naked eye.
 - C An example of a waterborne disease is cholera.
 - D Washing hands and sterilizing can prevent the spread of diseases.
- (1)

1.1.6 Jade wants to test whether the gas produced during an experiment is carbon dioxide gas. Which one of the following reactants can Jade use to test for the presence of carbon dioxide gas?

- A Copper hydroxide.
 - B Milky white lime water.
 - C Clear lime water.
 - D Iodine solution.
- (1)

1.1.7 Which one of the following symbols represents hydrogen?

- A Hg
 - B He
 - C Hy
 - D H
- (1)

1.1.8 Protons and neutrons are responsible for the ... of an atom.

- A mass
 - B volume
 - C density
 - D size
- (1)

1.1.9 Which one of the following is NOT an example of a compound?

- A H₂O
 - B O₂
 - C CuCl₂
 - D CO₂
- (1)

1.1.10 Sea water is an example of a(n) ...

- A atom.
 - B compound.
 - C mixture.
 - D element.
- (1)

[10]

QUESTION 2

2.1 Give ONE word/term for each of the following descriptions. Write only the correct word/term next to the question number (2.1.1 – 2.1.5) in your ANSWERBOOK.

2.1.1 When all the individuals of a species die out. (1)

2.1.2 A type of food sugar, produced by plants during photosynthesis. (1)

2.1.3 Body covering that makes an animal hard to see. (1)

2.1.4 A live animal that is hunted. (1)

2.1.5 The introduction of a substance which can contribute to an imbalance in an ecosystem. (1) [5]

QUESTION 3

3.1 Choose the description in COLUMN B that best matches the item in COLUMN A. Only write down the letter (A - I) next to the correct question number (3.1.1 – 3.1.5) in your ANSWER BOOK, e.g. 3.1.6 J.

COLUMN A	COLUMN B
3.1.1. Proton	A. Compound
3.1.2. Atom	B. Negatively charged sub-atomic particle
3.1.3. Electron	C. Positively charged sub-atomic particle
3.1.4. Molecule	D. Sub-atomic particle that has no charge
3.1.5. Density	E. Two or more atoms chemically bonded
	F. Smallest building block of matter
	G. Element
	H Mass per unit volume
	I Measured in gram per cm ²

[5]

TOTAL SECTION A: 20

SECTION B**QUESTION 4**

The graph below shows the number of Tuberculosis (TB) patients with known HIV status in South Africa, for the period 2004 to 2006. The diseases mentioned are caused by micro-organisms. Study the graph and answer the questions that follow.

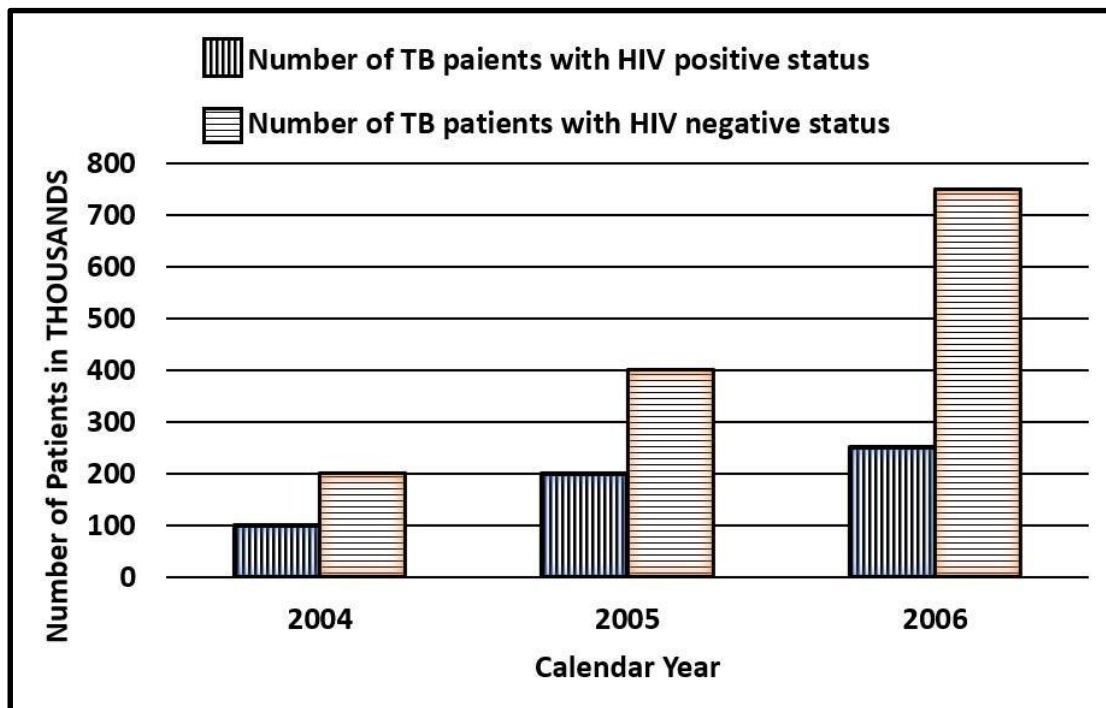

- 4.1 What was the TOTAL number of patients with Tuberculosis (TB) in the year 2006? (1)
- 4.2 How many TB patients were diagnosed HIV-positive in 2006? (1)
- 4.3 Is the prevalence of TB patients that are diagnosed positively with HIV increasing or decreasing? Explain your answer by comparing the data in the graph for the years 2004, 2005 and 2006. (2)
- 4.4 AIDS and TB are caused by harmful micro-organisms. Identify the type of micro-organism that causes:
- 4.4.1 AIDS (1)
- 4.4.2 TB (1)
- 4.5 Some micro-organisms are classified as useful to human beings. Name TWO ways in which they are used to our advantage. (2)
- 4.6 Name TWO ways in which the spread of AIDS can be prevented or minimised. (2)

[10]**QUESTION 5**

The diagram below represents important cellular processes that take place in green plants. Complete the table by writing down the number and correct answer.

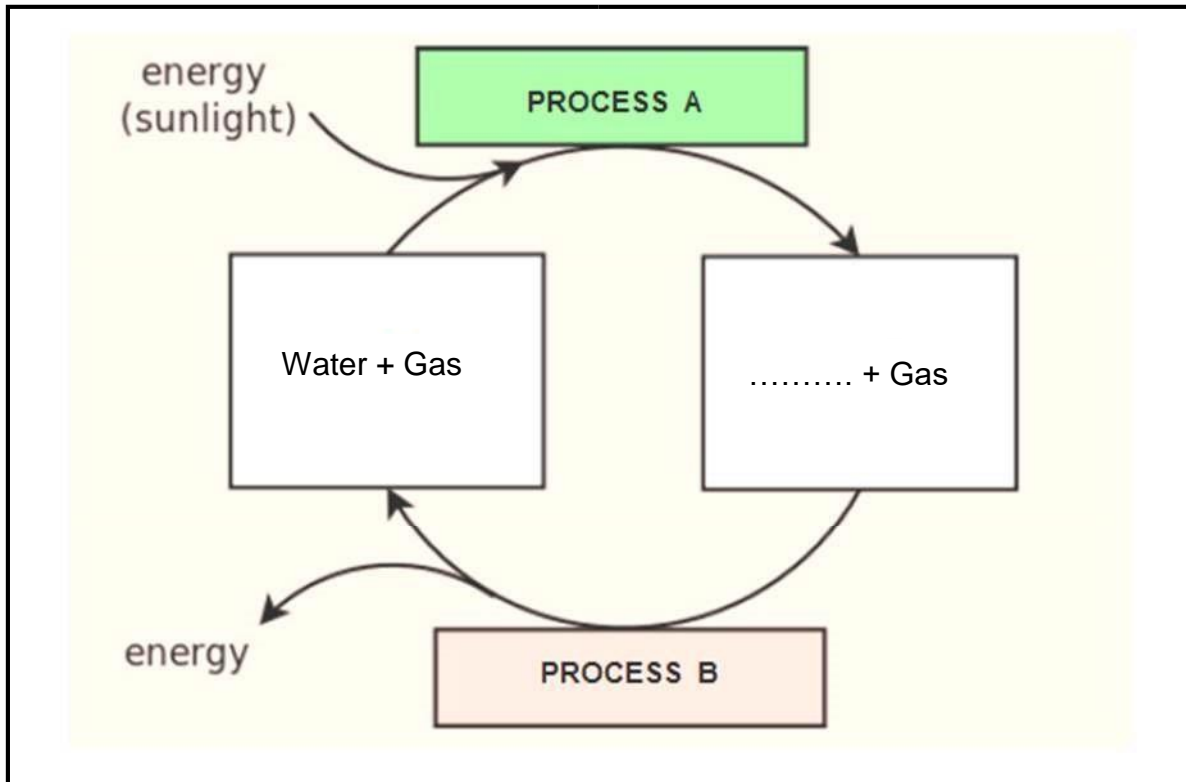

STATEMENT	PROCESS A	PROCESS B
Name process B.	Photosynthesis	5.1
Name the important gases that are needed in each of the processes.	5.2	5.3
Name the gas that is released by each process.	5.4	5.5
Name the main usable product formed by each process.	5.6	5.7

[7]

QUESTION 6

Study the diagram below and answer the questions that follow.

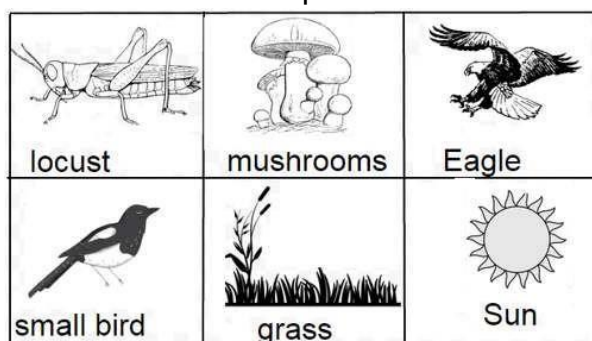

6.1 Write down the name of one herbivore that is found in the diagram. (1)

- 6.2 Write down the name of a decomposer that is found in the diagram. (1)
- 6.3 Write down a food chain consisting of five different organisms found in the diagram. Do not redraw the pictures. Use the words given in the diagram. (3)
- 6.4 Are plants or animals the better source of energy for humans? Explain your choice by referring to the trophic levels in which plants and animals are found. (3)
- [8]**

QUESTION 7

- 7.1 Write down the symbol for each of the following elements:

7.1.1 Oxygen (1)

7.1.2 Nitrogen (1)

- 7.2 Classify each of the following substances (A, B, C and D) as either a mixture, an element or a compound.

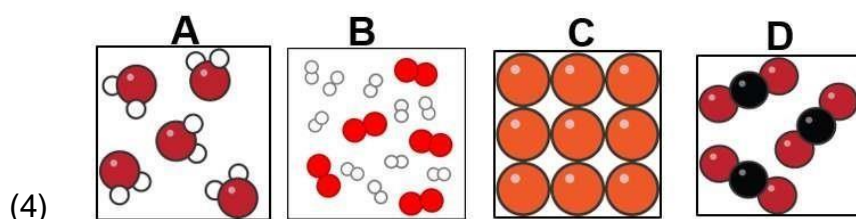

- 7.3 Use the particle model of matter to describe the behaviour of water particles when water is heated and changes from a LIQUID to a GAS. In your answer, refer to the kinetic energy of the particles, the movement of the particles, the open spaces between the particles and the forces that exist between the particles. (4)

[10]

QUESTION 8

Phakisi and Tristan want to find out what effect an electric current will have on a blue copper chloride solution. Phakisi predicts that an electric current will break up the copper chloride into copper and chlorine.

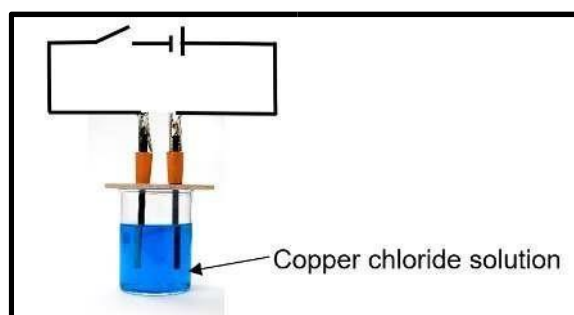

- 8.1 Write down an investigative question for the experiment above. (2)
- 8.2. Define the term electrolysis. (2)
- 8.3 Describe your observations at the positive electrode (anode). (2)
- 8.4 Write down the formula for chlorine gas. (1)
- 8.5 Describe the energy conversion that occurs during the process above. (2)
- 8.6 Is the blue copper chloride solution an example of an ATOM or a COMPOUND or a MIXTURE? Write down the correct option in your answer book. (1)

[10] QUESTION 9

A lady orders a drink in a restaurant. When the waiter brought her drink, she noticed that she could see three different layers of liquids, as shown in the diagram below. Study the diagram and answer the questions that follow.



- 9.1. Define the term density. (2)
- 9.2 Will the density of matter increase or decrease when it is heated?
Explain your answer by referring to the definition of density. (2)
- 9.3. Which one of the three layers in the diagram, has the highest density? (1)
[5]

TOTAL SECTION B: 50
GRAND TOTAL: 70

INFORMATION SHEET:

TABLE 3: THE PERIODIC TABLE OF ELEMENTS/TABEL 3: DIE PERIODIEKE TABEL VAN ELEMENTE

1	2	3	4	5	6	7	8	9	10	11	12	13	14	15	16	17	18
(I)	(II)								(III)	(IV)	(V)	(VI)	(VII)	(VIII)			
1 H 1																	2 He 4
3 Li 7	4 Be 9												6 C 12	7 N 14	8 O 16	9 F 19	10 Ne 20
11 Na 23	12 Mg 24											13 Al 27	14 Si 28	15 P 31	16 S 32	17 Cl 35,5	18 Ar 40
19 K 39	20 Ca 40	21 Sc 45	22 Ti 48	23 V 51	24 Cr 52	25 Mn 55	26 Fe 56	27 Co 59	28 Ni 59	29 Cu 63,5	30 Zn 65	31 Ga 70	32 Ge 73	33 As 75	34 Se 79	35 Br 80	36 Kr 84
37 Rb 86	38 Sr 88	39 Y 89	40 Zr 91	41 Nb 92	42 Mo 96	43 Tc 101	44 Ru 101	45 Rh 103	46 Pd 106	47 Ag 108	48 Cd 112	49 In 115	50 Sn 119	51 Sb 122	52 Te 128	53 I 127	54 Xe 131
55 Cs 133	56 Ba 137	57 La 139	72 Hf 179	73 Ta 181	74 W 184	75 Re 186	76 Os 190	77 Ir 192	78 Pt 195	79 Au 197	80 Hg 201	81 Tl 204	82 Pb 207	83 Bi 209	84 Po 209	85 At 210	86 Rn 222
87 Fr 223	88 Ra 226	89 Ac 227															

58 Ce 140	59 Pr 141	60 Nd 144	61 Pm	62 Sm 150	63 Eu 152	64 Gd 157	65 Tb 159	66 Dy 163	67 Ho 165	68 Er 167	69 Tm 169	70 Yb 173	71 Lu 175
90 Th 232	91 Pa 231	92 U 238	93 Np 237	94 Pu 242	95 Am 243	96 Cm 247	97 Bk 247	98 Cf 251	99 Es 252	100 Fm 257	101 Md 288	102 No 289	103 Lr 260

Atomic number
Atoomgetal

Electronegativity
Elektronegatiwiteit

Symbol
Simbool

29
Cu
63,5

Approximate relative atomic mass
Benaderde relatiewe atoommassa